

Dynamic Dual Head™ (DDH)

Patented, Unrivaled Technology

The proprietary design of Dynamic Dual Head (DDH) provides the only fast and fully accurate solution for dual head simultaneous dispensing. The DDH option uses a unique and patented mini XY drive system on a second Z-Axis to correct “real-time” and allow synchronous dispensing of both pumps regardless of part to part rotation. This technique guarantees increased productivity whilst maintaining yields through unsurpassed accuracy.

Features

- Independent, real time adjustment for both dispense pumps
- Dispense productivity increased by up to 100%
- No yield loss due to second head accuracy
- Compatible with all dispense pumps
- Automatic setup and calibration

Leading Edge Innovation

Camalot is a proven innovator in advancing dispenser technology, the associated patents to DDH increase our portfolio to over 50 inventions. These provide customer driven solutions to improve and extend the capability of our platforms towards the challenges within the manufacturing environment.

These patents include:

- 7,833,572** Asynchronous (alternate) dispensing with multiple pumps
- 8,230,805** Determining substrate alignment prior to synchronous dispensing
- 9,374,905** Automatic pitch adjustment of multiple dispense pumps to allow synchronous dispensing
- 9,775,250** Automatic theta adjustment of multiple pumps to allow synchronous dispensing

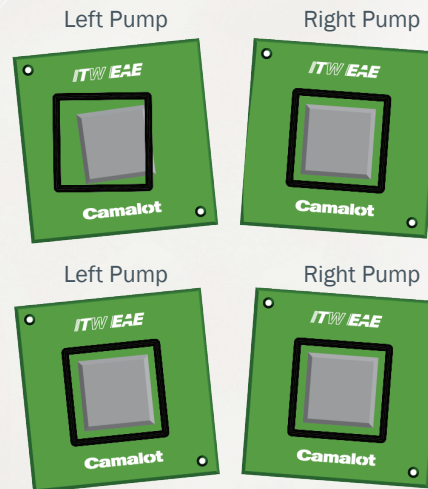

Normal dual head dispense result

Fully corrected alignment with DDH operation

The example above demonstrates the correction capability of DDH with Semiconductor packages. This technique also provides the same level of adjustment and rotational correction for all step and repeated PCB's, flex circuits and panel designs.

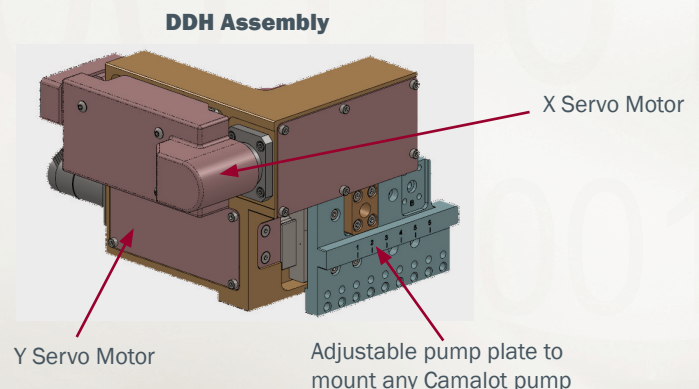

Dynamic Dual Head™ (DDH)

FAQs



NuJet pumps pitched at 28mm

Q: Why is the DDH technology “unique” to other alternatives in the Market?

A: The associated Patents to DDH ensure that Camalot are the only supplier who can offer real-time correction for synchronous dispensing of two or more Dispense pumps, other alternatives are limited to a one-time correction prior to dispensing that does not compensate for rotation between substrates

Q: How do I know if DDH will work for my products

A: DDH will work for all applications where identical PCB's/Substrates are pitched within the options specification. The option is targeted towards Semiconductor, Automotive and Smart-Phone markets but it's broad flexibility will suit most dispensing requirements of the electronics assembly industry. Please contact your local Representative with any questions or contact us directly through the web site

Q: What pumps can DDH be used with?

A: DDH is compatible with all Camalot pumps

Q: What platforms is the DDH available on?

A: DDH is only available on the Prodigy dispensing system and field upgradable for existing Prodigy customers



DDH SPECIFICATIONS

Voltage	48 vdc
Drive system	DC Servo & ballscrew
Drive controls	Trap amps, 7/10 cont/peak, 500 W
Encoder resolution	< 1 micron
Individual axis repeatability	+/- 1 micron
Pitch (pump dependant)	28 mm - 140 mm
Max Speed	10 mm/s
Platform compatibility	Prodigy (Upgradeable)
Pump compatibility	All Prodigy pumps
Load capacity	1.6 kgs (3.5 lbs)

Call your local representative for further details.

ITW EAE is a division of Illinois Tool Works, Inc. It is a consolidation of all of its Electronic Assembly Equipment and Thermal Processing Technology. The group includes world-class products from MPM, Camalot, Electrovert (Speedline), Vitronics Soltec and Despatch.